

EVOLUTION™ SERIES FLOOR BOXES



Wiremold® Evolution™ Series Floor Boxes are the latest advancement in the most complete and innovative line of floor solutions in the industry.



CODE REFERENCE

cULus Listed
Metallic Outlet Boxes:
 File E2961 Guide QCIT.
 Meets Article 314.27(C) of NEC.

Evolution™ Series Floor Box Components

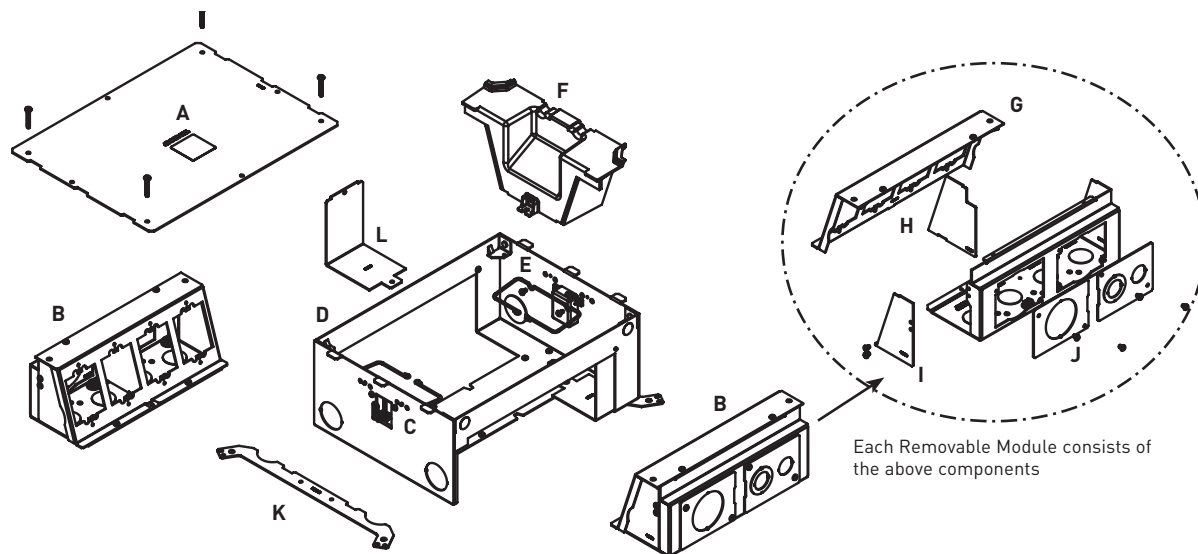

KEY

- | | |
|---|---------------------------------------|
| A. Mud Cap (temporary construction cover) | G. Mounting Bracket |
| B. Removable Module | H. Divider (removable repositionable) |
| C. Toggle Clamp | I. End Cap |
| D. Box | J. Back Knockout Plate |
| E. Cable Guide | K. Concrete Level Leg |
| F. Tunnel | L. "L" Bracket |

All items shown above are included with Evolution Series floor boxes.

COLOR OPTIONS



Evolution Series Floor Box Covers are available in the following powder coated finishes: "BK" black, "GY" gray, "NK" nickel, "BS" brass, and "BZ" bronze.

Custom color options are also available. Consult the factory for more information.

EVOLUTION™ SERIES FLOOR BOXES

Evolution™ Series 6-Gang Floor Boxes Ordering Information (continued)

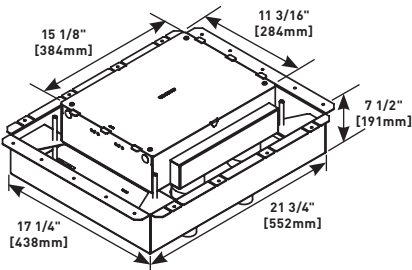
EFB6S-FC Six-Gang Fire-Classified Floor Box

Designed to be installed in above grade concrete floors while maintaining the fire classification of the floor. This box is classified to be used in 2-hour fire rated floors. Designed to accept standard size wall plates. **Box comes complete with all components needed for initial installation. Included components are:** protective/disposable cover, tunnel system for connecting the two modules of compartments, fire classified pan, two (2) removable modules, four (4) 1 1/4 intumescent conduit feeds and two (2) cable management guides. **Items not included with the box and sold separately are:** receptacles, communication jacks, and A/V devices and device plates

NOTE: For use on bare (polished) concrete or terrazzo floors EFB610-CTR must be used. (Sold separately).

NOTE: Designed for new construction applications.

NOTE: Consult structural engineer before making cuts into decking. Add additional supports as instructed by the structural engineer.

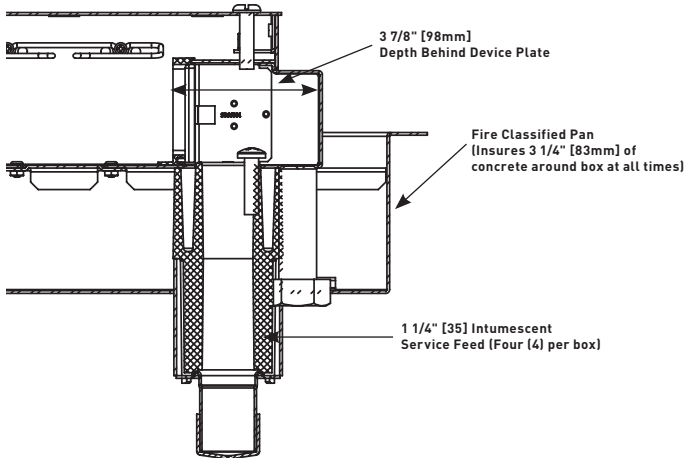
**Outlet Boxes and Fittings Classified for Fire Resistance Legrand/Wiremold (R8209)**

Type EFB6S-FC, EFB8S-FC and EFB10S-FC preset electrical insert for use in 2-hour fire rated D900 Series Floor-Ceiling designs constructed with nominal 2" or 3" deep fluted steel floor units having a nominal 5" wide valley and crests spaced 12" OC, with a minimum 3 1/4" [83mm] thickness of structural concrete topping. The assembly preset electrical insert with floor plate kit and service activations fitting will not reduce the 2-hour fire rating of the floor assembly when installed in accordance with the installation instructions accompanying the preset electrical insert and when the preset electrical insert are spaced 2' [0.61m] OC with not more than one unit per 4 square feet [0.37m²] of floor area in each span.

Evolution™ Series 6-Gang Floor Box Accessories Ordering Information

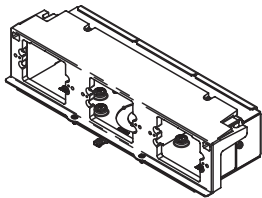
EFB6M Module

Bank of three (3) compartments that accept power, communications and audio/video devices. Accepts standard size (2 3/4" x 4 1/2" [70mm x 114mm]) device plates. Includes device bracket, back plate, three (3) knockout plates (3/4"/1 1/4" concentric), two (2) end caps and one (1) divider.

NOTE: Module will fit on either side of the floor box.

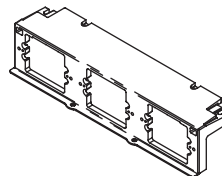
EFB6-MB Mounting Bracket

Holds up to three (3) devices of power, communications or audio/video devices. Bracket accepts standard size (2 3/4" x 4 1/2" [70mm x 114mm]) device plates sold separately by others.

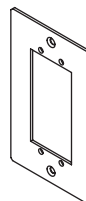
EFB-AAP Device Plate

Holds two (2) Extron® Electronics AAP devices. Device plate dimensions: 2 3/4" x 4 1/2" [69mm x 114mm].